

RECOMMENDED PCB LAYOUT

MATERIALS:

1. Housing: Thermoplastic (UL 94V-0)
2. Contacts: Brass, Gold Plated on Contact Area
Sn Plated on Solderails
Nickel Under Plated Over All
3. Shell: SPCC, Nickel Plated
4. Rivet: Copper Alloy, Nickel Plated
5. Board Lock: SPCC, Sn Plated Over Nickel

SPECIFICATION:

1. Contact Current Rating: 1.5 Amp
2. Dielectric Withstanding Voltage: AC 500V r.m.s.
3. Insulation Resistance: 1000mΩ Min. at DC 500V
4. Contact Resistance: 30mΩ Max.
5. Operating Temperature: -20°C to 85°C

ORDER INFORMATION:

D 7 1 X X - 24 F - 1 X 0 R
① ② ③

- ① 1=W / O(Without Screw)
2=W / S(Lock Screw)
3= W / O(Annex Screw)
- ② 0=(Without Screw)
1=(4.8mm / 11.80mm) SPCC Screw
2=(5.8mm / 13.00mm) SPCC Screw
A=(4.8mm / 11.80mm) Copper Alloy Screw
B=(5.8mm / 13.00mm) Copper Alloy Screw
- ③ 1=Ivory / PBT
2=Ivory / PBT+High Temperature
3=Ivory / High Temperature

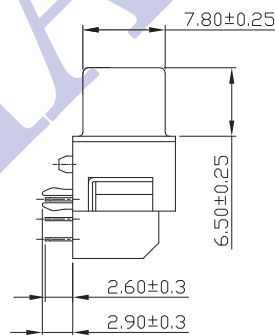
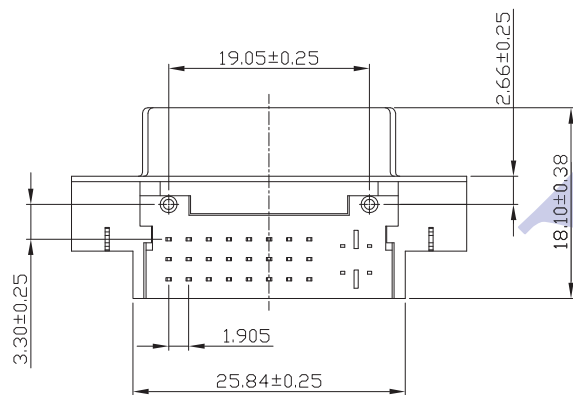

D7110 (鉚合無螺絲)

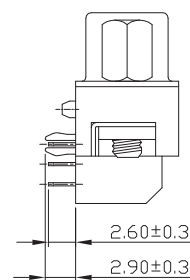

D712X (鉚合鎖螺絲)

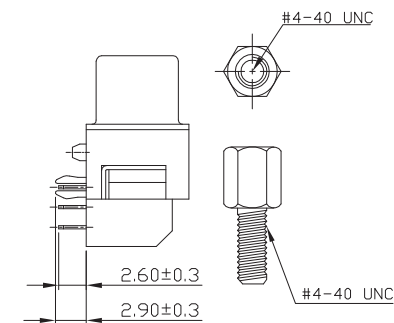

D713X (鉚合附螺絲)

XIAN YI PRECISION CO., LTD.

祥益精密股份有限公司

TITLE / 品名: DVI 24P(2.66mm) Right Angle(R/A) Dip Connector

PART NO / 料號: D71XX-24F-1X0R

APPROVE / 核準	CHECKED / 審查	DRAWING / 繪圖	DRAWING NO / 圖號	UNIT / 單位		<p>GENERAL TOLERANCE</p> <p>X ±0.50</p> <p>.X ±0.38</p> <p>.XX ±0.20</p> <p>.XXX ±0.10</p>	A.0 圖面發行	2011/05/09	核準發行章
James	James	Cherong	L-024	mm					

僅供參考