

D1110 (鉗合無螺絲)

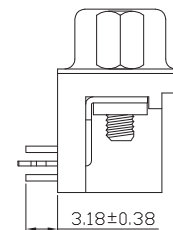

D112X (鉗合鎖螺絲)

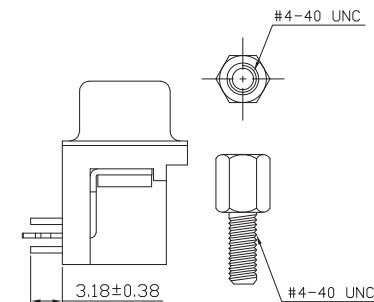

D113X (鉗合附螺絲)

MATERIALS:

1. Housing: Thermoplastic (UL 94V-0)
2. Contacts: Brass, Gold Plated on Contact Area
Sn Plated on Solderails
Nickel Under Plated Over All
3. Shell: SPCC, Nickel Plated
4. Rivet: Copper Alloy, Nickel Plated
5. Board Lock: SPCC, Sn Plated

SPECIFICATION:

1. Contact Current Rating: 3A
2. Dielectric Withstanding Voltage: AC 500V r.m.s.
3. Insulation Resistance: 5000mΩ Min. at DC 500V
4. Contact Resistance: 30mΩ Max.
5. Operating Temperature: -55°C to 105°C

ORDER INFORMATION:

D 1 1 X X - 25 M - 1 X 0 R
① ② ③

- ① 1=W / O(Without Screw)
2=W / S(Lock Screw)
3= W / O(Annex Screw)
- ② 0=(Without Screw)
1=(4.8mm / 11.80mm) SPCC Screw
2=(5.8mm / 13.00mm) SPCC Screw
A=(4.8mm / 11.80mm) Copper Alloy Screw
B=(5.8mm / 13.00mm) Copper Alloy Screw
- ③ 1=Black / PBT
2=PC99 / PBT

XIAN YI PRECISION CO., LTD.
祥益精密股份有限公司

TITLE / 品名: D-Sub 25M(8.08mm) Right Angle(R/A) Dip Type Connector

PART NO / 料號: D11XX-25M-1X0R

核準發行章
僅供參考

APPROVE / 核準	CHECKED / 審查	DRAWING / 繪圖	DRAWING NO / 圖號	UNIT / 單位		GENERAL TOLERANCE X ±0.50 .X ±0.38 .XX ±0.20 .XXX ±0.10	A. 0 圖面發行	2011/05/09						
James	James	Chenrong	L-009	mm					SHEET 1 OF 1	NO. REV / 版本	修訂內容	日期		
8	1	7	1	6	1	5	1	4	1	3	1	2	1	1